

AYENSO POMPA



AY-9-3-M

PARÇA LİSTESİ

	KOD	PARÇA ADI	MALZEME
1	AY-9-3-M-M	Motor	3 kw
2	AY-9-3-M-F	Flanş	PP
3	AY-9-3-M-AK	Arka Kapak	PP
4	AY-9-3-M-MD	Manyetik Disk	Çelik
5	AY-9-3-M-AD	Ara Disk	PP/ PVC/ PVDF/ PE
6	AY-9-3-M-P	Pul	Seramik
7	AY-9-3-M-Ş	Şaft	Seramik
8	AY-9-3-M-O	O-ring	Viton/ EPDM
9	AY-9-3-M-C	Çark	PP/ PVC/ PVDF/ PE
10	AY-9-3-M-S	Salyangoz	PP/ PVC/ PVDF/ PE
11		Civata+pul+somun	AISI 304

TEKNİK ÖZELLİKLER

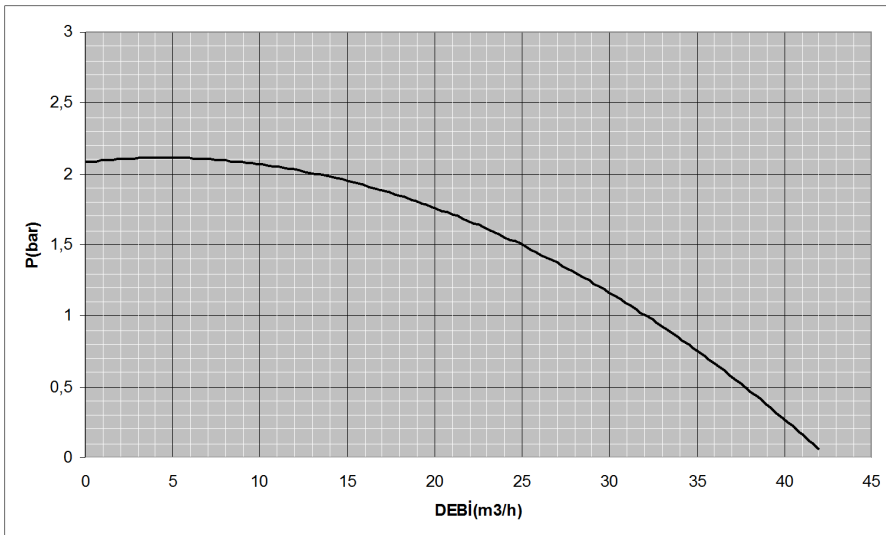
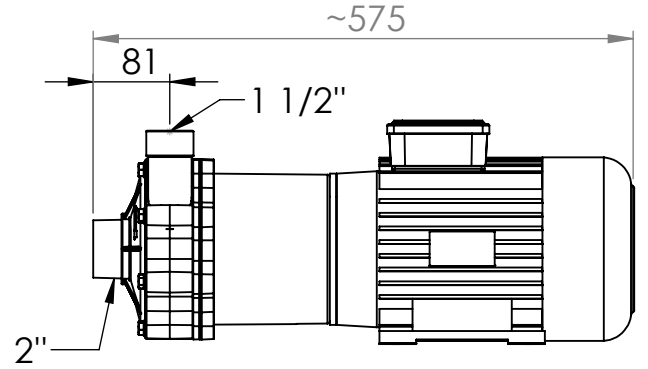
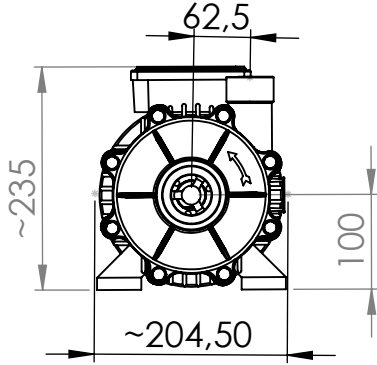

Max. Basınç	2,1 bar
Max. Debi	42 m³/h
Toplam Ağırlık	28,5 kg
Güç	3 kW
Voltaj	400 V
Frekans	50 Hz.
Faz	3
Devir	2850 RPM
Koruma Sınıfı	IP55